

Make the ERC happy

Prototype 1
Jannik Beyerstedt (jtbx)

Sheet: /
 File: c3lingo_unit-assembly.sch

Title: c3lingo interpreter unit

Size: A4 Date: 2021-05-28
 KiCad E.D.A. kicad (5.1.10-1-10_14)

Rev: v0.2
 Id: 1/5

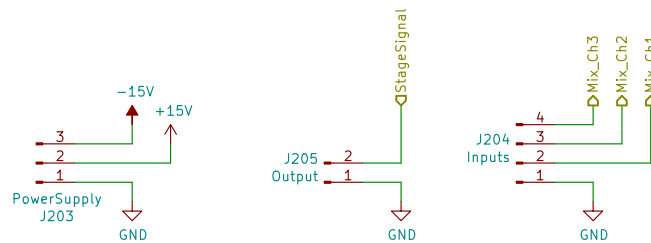
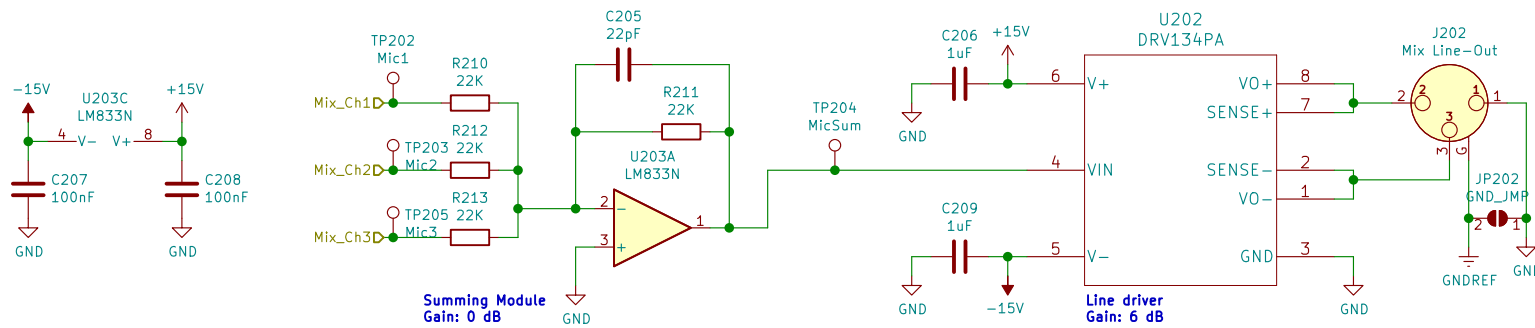
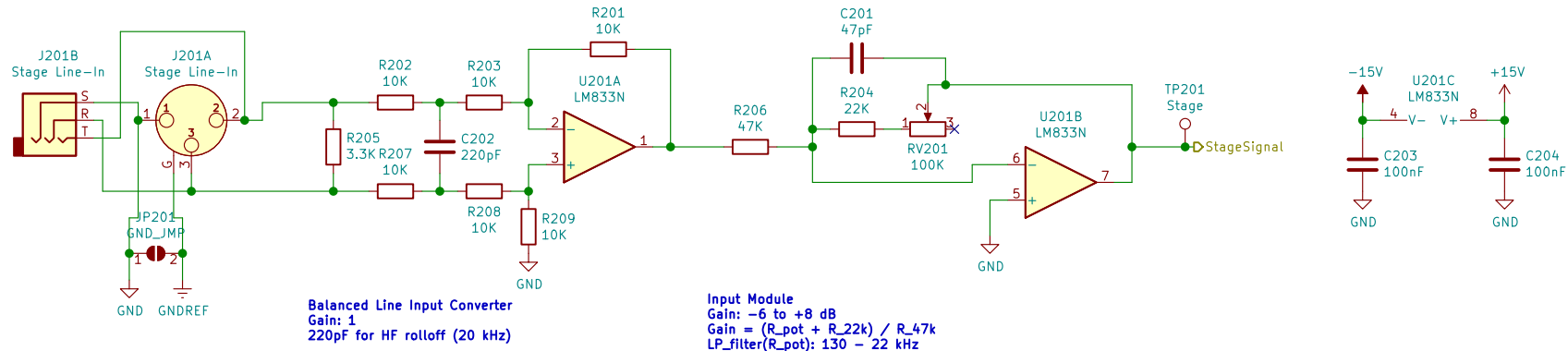

Prototype 1		
Jannik Beyerstedt (jtbx)		
Sheet: /Stage Line In + Microphone Mix and Line Out/		
File: c3lingo_unit-mix_io.sch		
Title: c3lingo interpetter unit -- mix and line I/O		
Size: A4	Date: 2021-05-28	Rev: v0.2
KiCad E.D.A. kicad (5.1.10-1-10_14)		Id: 2/5

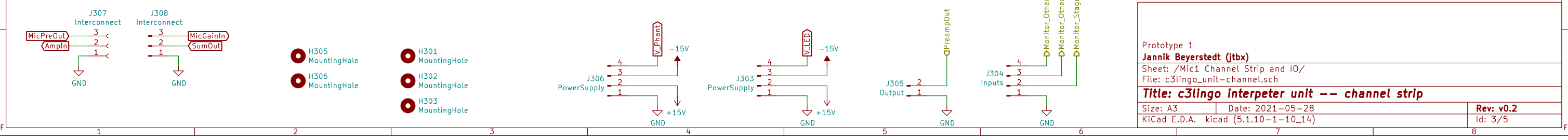
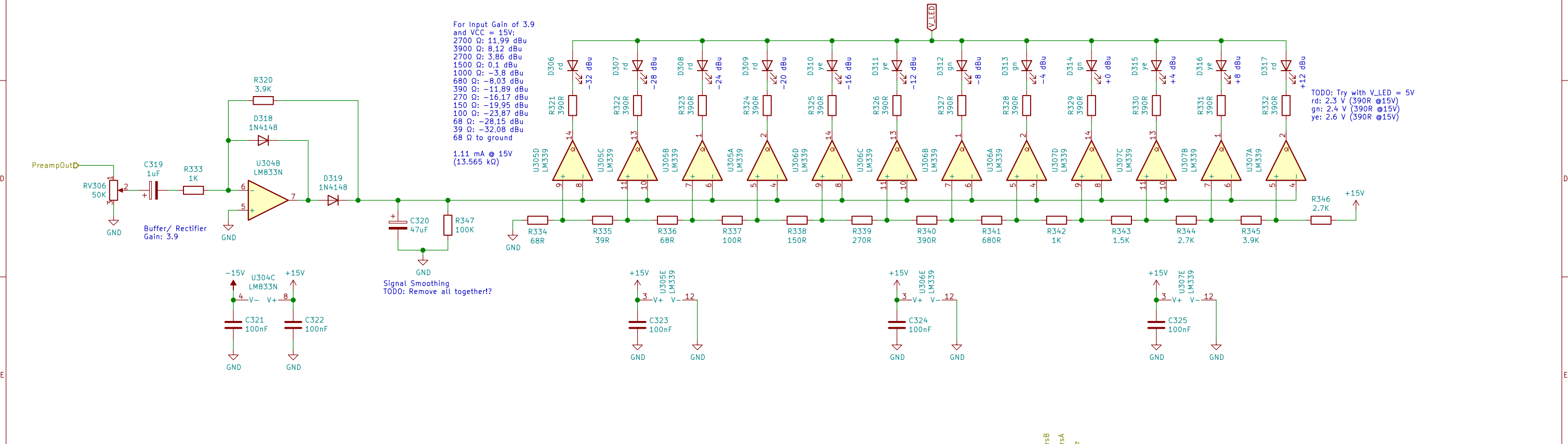
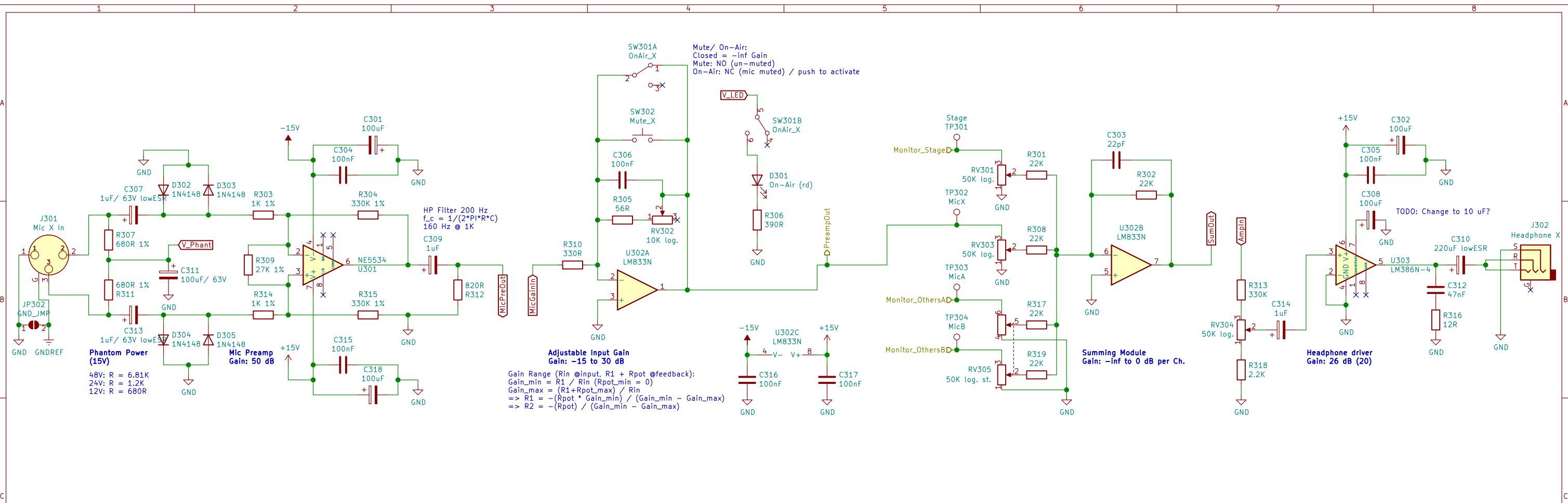

Prototype 1
Jannik Beyerstedt (jtbx)
 Sheet: /Mic1 Channel Strip and IO/
 File: c3lingo_unit-channel.sch
Title: c3lingo interpreter unit -- channel strip
 Size: A3 Date: 2021-05-28 Rev: v0.2
 KiCad E.D.A. kicad (5.1.10-1-10_14) Id: 3/5

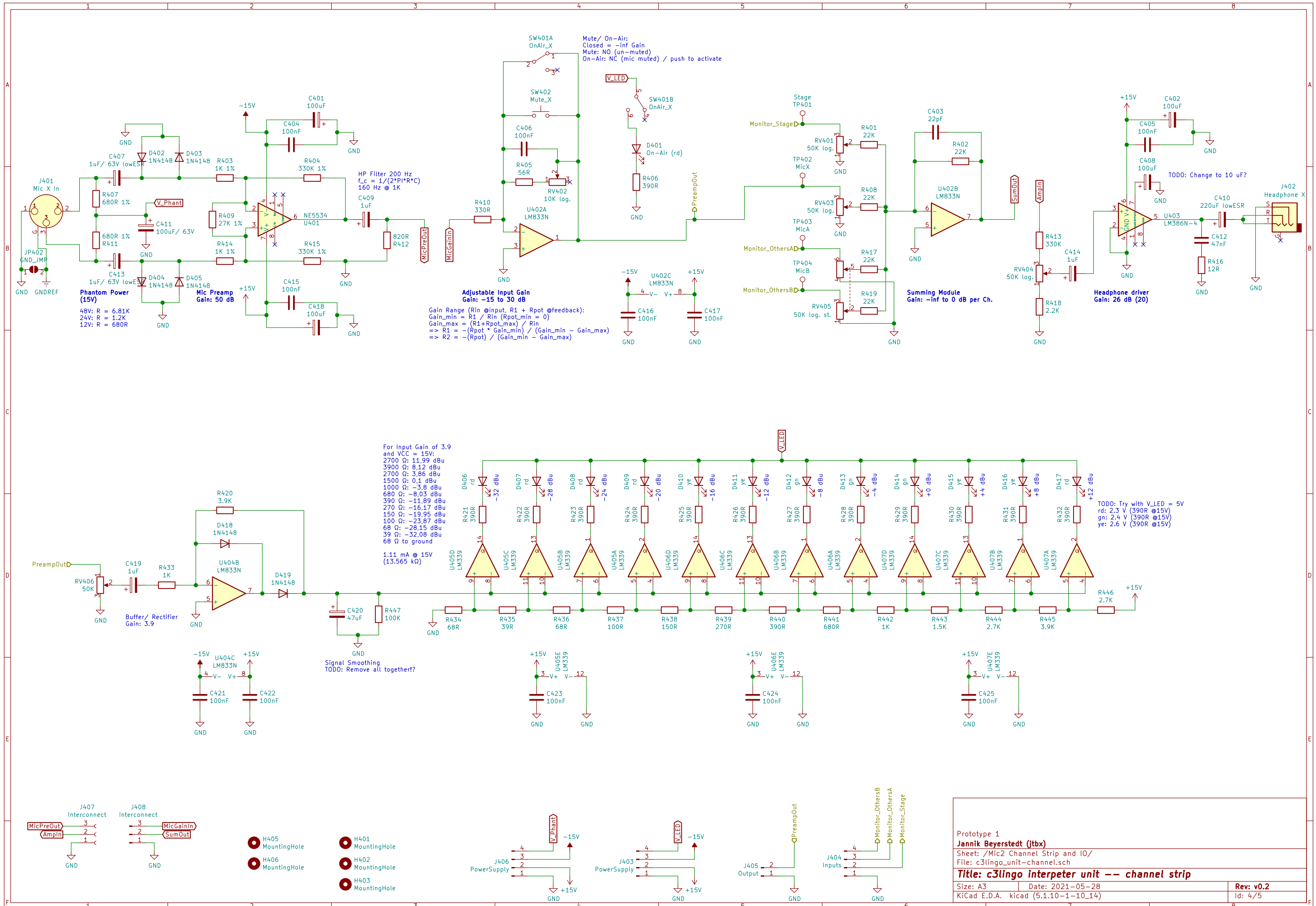

Prototype 1		
Jannik Beyerstedt (jtbx)		
Sheet: /Mic2 Channel Strip and IO/ File: c3lingo_unit-channel.sch		
Title: c3lingo interpeter unit -- channel strip		
Size: A3	Date: 2021-05-28	Rev: v0.2
KiCad E.D.A. kicad (5.1.10-1-10_14)		Id: 4/5

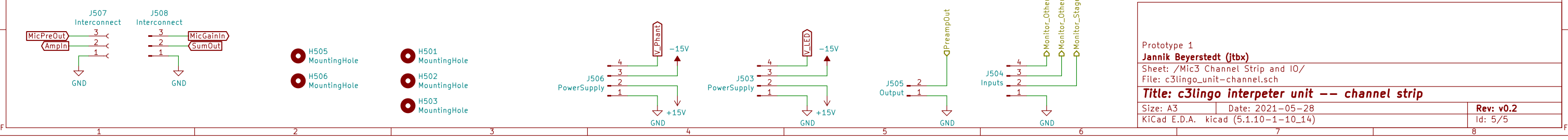
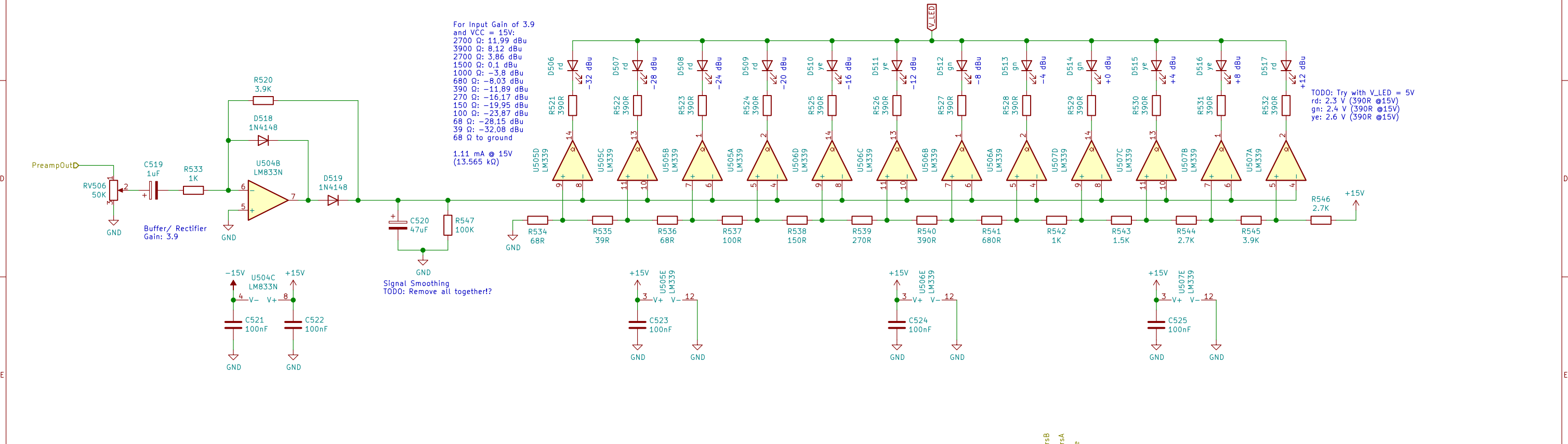
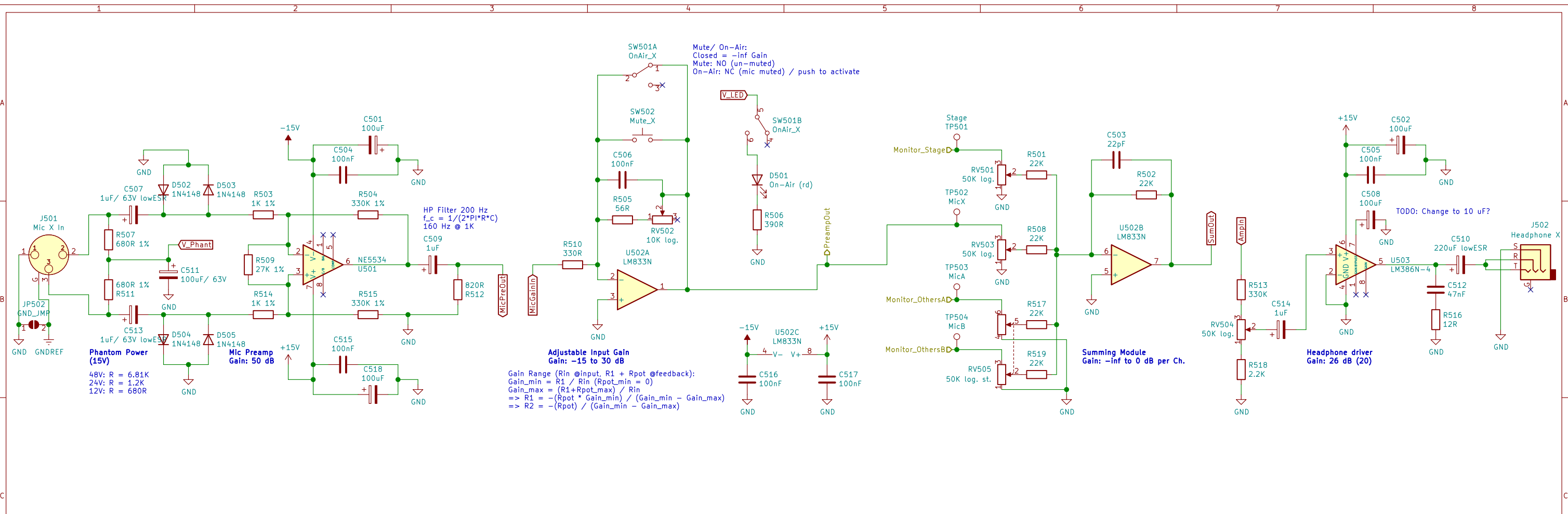

Prototype 1		
Jannik Beyerstedt (jtbx)		
Sheet: /Mic3 Channel Strip and IO/ File: c3lingo_unit-channel.sch		
Title: c3lingo interpeter unit -- channel strip		
Size: A3	Date: 2021-05-28	Rev: v0.2
KiCad E.D.A. kicad (5.1.10-1-10_14)	Id: 5/5	